



ASHOK LEYLAND

Koi Manzil Door Nahin

2825 SERIES 6X4 TIPPERS

**BUILD YOUR
OWN TIPPER**



2825 TM

2825 TU

2825 TN



Best-in-class
productivity



Higher durability



Superior TCO



HINDUJA GROUP

SPECIFICATIONS

Engine type	A series BS-VI with 4 cylinder i-Gen6 technology	H series BS-VI with 6 cylinder i-Gen6 technology
Engine power	185 kW @ 2200rpm (250HP)	184 kW @ 2400rpm (250HP)
Engine torque	900Nm @ 1100 - 1800rpm	900Nm @ 1200 - 1900rpm
Clutch	395mm dia with air assisted hydraulic booster	380mm dia with air assisted hydraulic booster
Gearbox	6 Speed - 2 options - FGR 8.91 and FGR 9.01 9 speed - 1 option - FGR 12.73	
Rear axle	Fully floating, single speed, hypoid differential RAR options: 5.57, 5.83, 6.5 and hub reduction 7.2 HR	
Suspension	Front option: semi-elliptic multileaf and parabolic springs Rear: NRS semi-elliptic and bogie	
Gradeability	Options available 46%, 48% and 64%	
TCD	14.3m / 16.6m	
Brake	Full air dual line with ABS with ASA, drum brakes with Engine brake	
Diesel tank capacity	220 L	
Chassis dimension	275mm x 75mm x 8mm	
Max speed	60 kmph	
Tyre options	295/90R20 295/95D20 11x20 16PR 11R20 16PR 11x20 mine lug 18PR	
Cabin options	M Cabin / U Cabin / N Cabin with AC option	
Chassis weights	Front Laden: 7000 kg Rear Laden: 21000 kg	

Wheelbase	3900mm	4600mm	3900mm	3900mm	3900mm	3900mm	4600mm
Body capacity	CAB CHASSIS	CAB CHASSIS	14 m ³ BOX & ROCK	16 m ³ Box	18 m ³ Box	20 m ³ Box	20 m ³ Box

SCHEMATIC LAYOUT

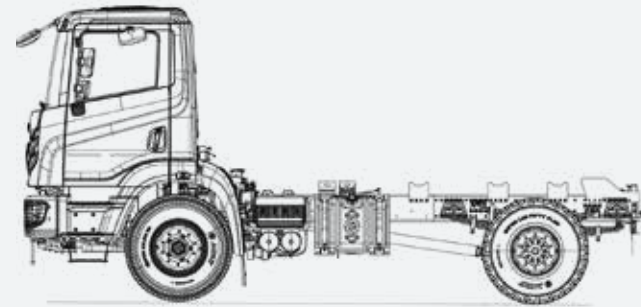

* Specification 2825 TN

ALERT RECON AMC ALCARE LEYPARTS[®] HELPLINE

LEYKART DRIVER TRAINING TECHNICAL TRAINING

ASHOK LEYLAND
Koi Manzil Door Nahin

Registered Office - Ashok Leyland Limited, No. 1, Sardar Patel Road,
Guindy, Chennai - 600032, Tel. - 91 44 2220 6000
E-mail - reachus@ashokleyland.com | Website - www.ashokleyland.com

HELPLINE
1800-266-3340

AUTHORISED DEALER