



ASHOK LEYLAND

Koi Manzil Door Nahin

PARTNER super

Your Partner for
SUPER PROSPERITY



Best-in-class
payload



Best-in-class
mileage



Proven 4 cylinder
16 valve ZD30
engine



Superior cabin
comfort



HINDUJA GROUP

ASHOK LEYLAND i-Gen6 ADVANTAGE

Over the years, Ashok Leyland has delivered an unparalleled performance with an Inline or 'Sada' pump for BS-III and iEGR technology for BS-IV. For BS-VI, we introduced i-Gen6 technology that further enhances the engine's performance and durability. With lower Diesel Exhaust Fluid (DEF) consumption and compact design, i-Gen6 lowers the cost of operation by providing best-in-class fluid efficiency. The unique Mid-NOx strategy ensures an overall lower cost of ownership and higher profitability.

Innovative



Improved efficiency -

- Controls NOx generation in the engine itself



Lower TCO -

- Lower Diesel Exhaust Fluid (DEF) consumption
- Lower operational cost

- Superior mileage: Proven iEGR engine with improved air intake and radiator offer higher performance
- Longer active regeneration intervals- ensures longer DPF life
- Inline EATS: Allows flexibility in packaging/ better space utilisation

Intelligent



Simple functioning -

- Lesser number of sensors



Improved EATS life -

- Patented HC dozer
- Lower maintenance cost

- 20 L Diesel Exhaust Fluid (DEF) tank: Coupled with lower consumption, ensures less frequent DEF refills
- Shorter first pipe length: Best-in-class thermal management

Indian



Mid-NOx technology -

- iEGR + SCR
- Higher fluid efficiency



Highly robust -

- Best suited for Indian driving conditions

PROVEN ZD30 ENGINE



- Proven Japanese technology
- Powerful and fuel-efficient
- 16 valves and DDTI: Double Overhead Camshaft, Direct Injection, Turbo Intercooled, which ensures superior performance
- Flat Torque ensures lesser gear shifts, fatigue free driving and better fuel efficiency

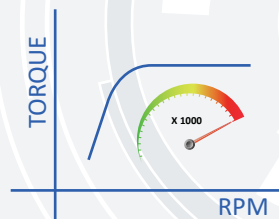

Flat Torque Available over Wide RPM

SUPER CABIN FEATURES



**4 point suspension -
for better driver comfort**



**Tiltable cabin in any gear
- ease of serviceability**



**Tiltable power
steering**

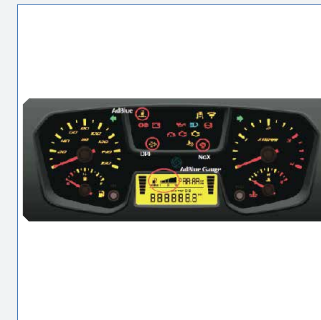

**Modern digital
cluster**

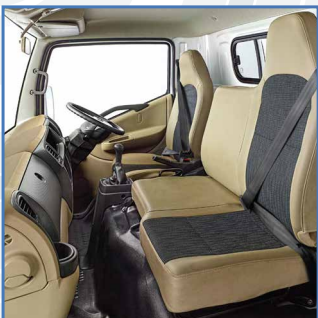

**Safe and ergonomic
interiors**



**Factory fitted
A.C. (Optional)**

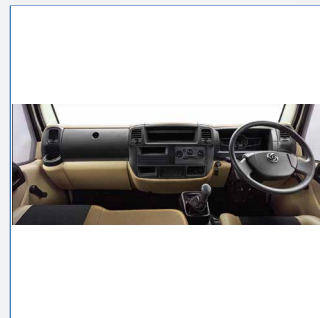

**Dual tone
dashboard**

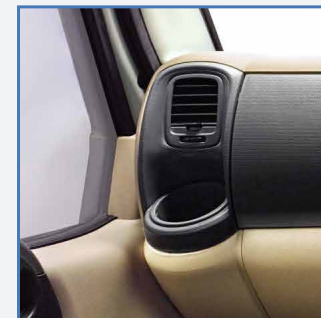

Bottle holder



Mobile charger

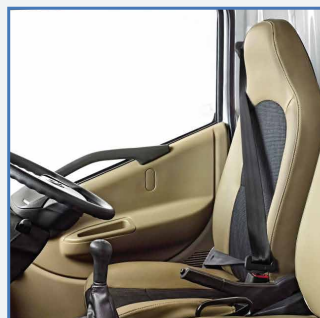

ELR seatbelt



Lockable glove box

SUPER AGGREGATE FEATURES



**6 speed overdrive
synchromesh gearbox**

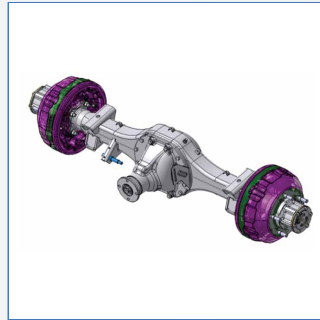

Heavy-duty axle



**Front parabolic suspension
with shock absorbers**



**Rear heavy-duty
semi-elliptical suspension
with helper springs**



**310 mm clutch
with unilever type booster**



**Monotron propeller shaft
with rubber mounted
centre bearing**

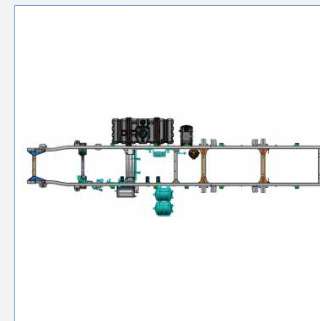

**High strength and long life
6 mm thick frame
joggled type**

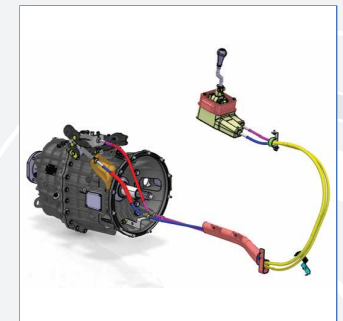

**Cable type shift
mechanism**

TECHNICAL SPECIFICATION

PARTNER SUPER 914	
Engine	ZD30 BS-VI Diesel with i-Gen6 technology
Maximum power	104 kW (140 hp) @ 2750 rpm
Maximum torque	360 Nm @ 1350-2750 rpm
Clutch	310 mm diameter - Diaphragm, Push type, Hydraulic actuated
Gearbox	6 speed overdrive, Cable type CSO
Propeller shaft	Monotron propeller shaft
Front axle	Forged I section - Reverse Elliot type
Rear axle	Fully-floating single speed rear axle, RAR 4.56
Steering	Hydraulic assisted power steering
Frame	202 mm x 60 mm x 6 mm - Joggled frame
Front suspension	Parabolic springs with shock absorber
Rear suspension	Semi-elliptic multileaf with helper springs
Brakes	Full air - dual line brakes, parking brakes on rear only
Electricals	Battery: 12 V - 75 Ah; Alternator: 70 A
Tyres	7.50 x 16-16 PR, Optional: 7.5R16 - 16PR
Fuel tank	90 L 185 L
DEF tank	20 L
Cabin	Tiltable day cab
GVW	9150 kg

Wheelbase (mm)	3425	3955	4500	4900
Loading span (m)	4.3 (14 ft)	5.2 (17 ft)	6.2 (20 ft)	6.8 (22 ft)
Turning circle diameter (m)	12.5	14.5	16.5	17.5

Load-body length (inner-mm)	4267	5173	6096	6706
Load-body width (inner-mm)	2074			
Load-body height (inner-mm)	1614			

Load body options

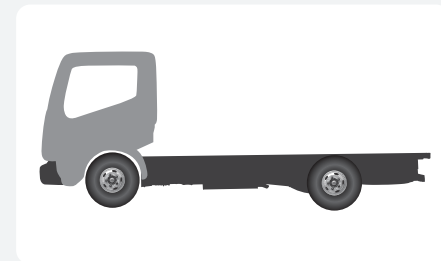

Cab Chassis (CBC)

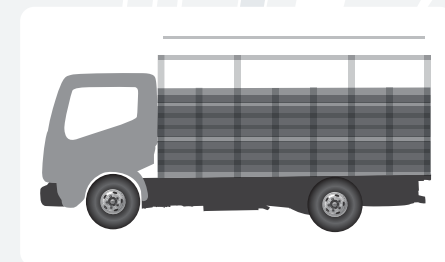

High Side Deck (HSD)

TECHNICAL SPECIFICATION

PARTNER SUPER 1014	
Engine	ZD30 BS-VI Diesel with i-Gen6 technology
Maximum power	104 kW (140 hp) @ 2750 rpm
Maximum torque	360 Nm @ 1350-2750 rpm
Clutch	310 mm diameter - Diaphragm, Push type, Hydraulic actuated
Gearbox	6 speed overdrive, Cable type CSO
Propeller shaft	Monotron propeller shaft
Front axle	Forged I section - Reverse Elliot type
Rear axle	Fully-floating single speed rear axle, RAR 5.13
Steering	Hydraulic assisted power steering
Frame	202 mm x 60 mm x 6 mm - Joggled frame
Front suspension	Parabolic springs with shock absorber
Rear suspension	Semi-elliptic multileaf with helper springs
Brakes	Full air - dual line brakes, parking brakes on rear only
Electricals	Battery: 12 V - 75 Ah; Alternator: 70 A
Tyres	8.25 x 16-16 PR, Optional: 8.25R16 - 16PR
Fuel tank	90 L 185 L
DEF tank	20 L
Cabin	Tiltable day cab
GVW	10250 kg

Wheelbase (mm)	3425	3955	4500	4900
Loading span (m)	4.3 (14 ft)	5.2 (17 ft)	6.2 (20 ft)	6.8 (22 ft)
Turning circle diameter (m)	12.5	14.5	16.5	17.5

Load-body length (inner-mm)	4267	5173	6096	6706
Load-body width (inner-mm)	2074			
Load-body height (inner-mm)	1614			

Load body options

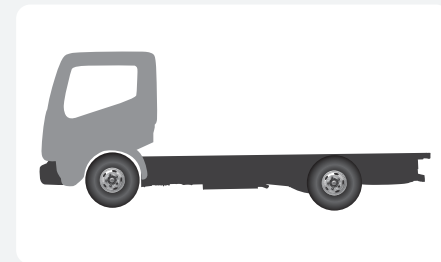

Cab Chassis (CBC)

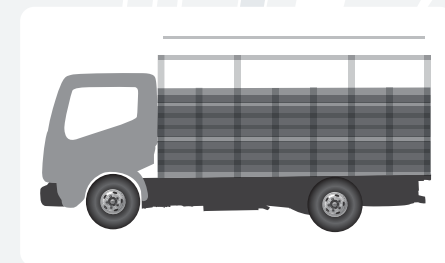

High Side Deck (HSD)

TECHNICAL SPECIFICATION

PARTNER SUPER 1114	
Engine	ZD30 BS-VI Diesel with i-Gen6 technology
Maximum power	104 kW (140 hp) @ 2750 rpm
Maximum torque	360 Nm @ 1350-2750 rpm
Clutch	310 mm diameter - Diaphragm, Push type, Hydraulic actuated
Gearbox	6 speed overdrive, Cable type CSO
Propeller shaft	Monotron propeller shaft
Front axle	Forged I section - Reverse Elliot type
Rear axle	Fully-floating single speed rear axle, RAR 5.13
Steering	Hydraulic assisted power steering
Frame	202 mm x 60 mm x 6 mm - Joggled frame
Front suspension	Parabolic springs with shock absorber
Rear suspension	Semi-elliptic multileaf with helper springs
Brakes	Full air - dual line brakes, parking brakes on rear only
Electricals	Battery: 12 V - 75 Ah; Alternator: 70 A
Tyres	8.25 x 16-16 PR, Optional: 8.25R16 - 16PR
Fuel tank	90 L 185 L
DEF tank	20 L
Cabin	Tiltable day cab
GVW	11280 kg

Wheelbase (mm)	3425	3955	4500	4900
Loading span (m)	4.3 (14 ft)	5.2 (17 ft)	6.2 (20 ft)	6.8 (22 ft)
Turning circle diameter (m)	12.5	14.5	16.5	17.5

Load-body length (inner-mm)	4267	5173	6096	6706
Load-body width (inner-mm)	2074			
Load-body height (inner-mm)	1830			

Load body options



Cab Chassis (CBC)

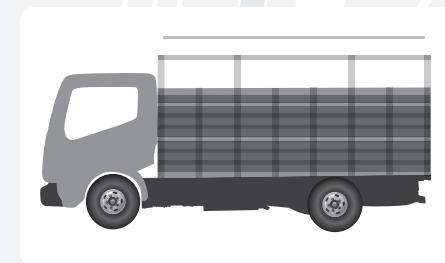

High Side Deck (HSD)

APPLICATIONS



Fruits and Vegetables



FMCG



Beverages



Auto Parts



Industrial Goods



Market Load



LPG Cylinder



Poultry



Dairy



White Goods

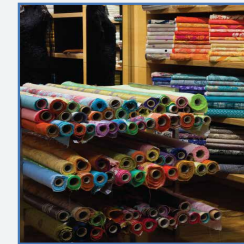

Textile

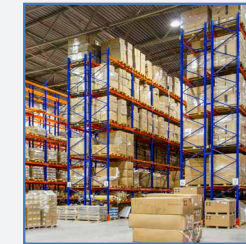

Courier and E-commerce



ALCARE

TECHNICAL TRAINING

HELPLINE

AMC

RECON

IALERT

LEYKART

LEYPARTS®

DRIVER TRAINING

AUTHORISED DEALER:

CIN: L34101TN1948PLC000105

Registered Office - Ashok Leyland Limited, No. 1, Sardar Patel Road, Guindy, Chennai - 600 032 | Tel. - 91 44 2220 6000

E-mail - reachus@ashokleyland.com | Website - www.ashokleyland.com | Helpline Number - 1800 266 3340